Industrial GPS Asset Tracker

User Guide

Document Type:	User Guide
Document Number:	T0006279_UG
Document Version:	1.2.r1
Product Name:	Industrial GPS Asset Tracker
Product Code:	T0006129 (NA/EU 2X D-Cell Industrial GPS Asset Tracker)
Issue Date:	May 13, 2020

PROPRIETARY:

The information contained in this document is the property of TEKTELIC Communications Inc. Except as specifically authorized in writing by TEKTELIC, the holder of this document shall keep all information contained herein confidential, and shall protect the same in whole or in part from disclosure to all third parties.

Table of Contents

- List of Tables3
- List of Figures4
- Acronyms and Glossary5
- 1 Product Description6
 - 1.1 Overview6
 - 1.2 Specifications.....7
- 2 Installation9
 - 2.1 Included Product and Installation Material9
 - 2.2 Safety Precautions9
 - 2.3 Unpacking and Inspection9
 - 2.4 Commissioning and Activation9
 - 2.5 Mounting10
 - 2.6 Battery Replacement11
- 3 Operation, Alarms, and Management12
 - 3.1 Configuration12
 - 3.2 Default Configuration.....12
 - 3.3 LED Behaviour.....12
 - 3.4 Activation, Putting to DEEP SLEEP, Resetting, and Shutting Down12
- 4 Compliance Statements14
- References16

List of Tables

Table 1-1-1: Industrial GPS Asset Tracker Model	6
Table 1-1-2: Industrial GPS Asset Tracker Specifications	7
Table 3-1: How to Activate, Put to DEEP SLEEP, Reset, or Shut Down Tracker.....	12

List of Figures

Figure 1-1: The Industrial GPS Asset Tracker module.....	7
Figure 2-1: The Tracker magnetic reset/wake-up pattern.....	10
Figure 2-2: The mounting holes and enclosure screw holes.....	11

Acronyms and Glossary

BeiDou	BeiDou Navigation Satellite System (BDS), a Chinese satellite navigation system
BER	bit error rate
BLE	Bluetooth Low Energy
bps	bits per second
DL	downlink
EIRP ...	equivalent isotropically radiated power
FCC	Federal Communications Commission
GLONASS	GLObal NAVigation Satellite System
GNSS ...	Global Navigation Satellite System
GPS	Global Positioning System
IoT	Internet of Things
IP	Ingress Protection
LED	light emitting diode
LoRa ...	a patented “long-range” IoT technology acquired by Semtech
LoRaWAN	LoRa wide area network (a network protocol based on LoRa)
LTC	lithium thionyl chloride (chemistry of LTC batteries)
MCU ...	microcontroller unit
NS	network server
OTA	over the air
PCBA ..	printed circuit board assembly
QZSS ..	Quasi-Zenith Satellite System
RF	radio frequency
RSS	Radio Standards Specifications
RSSI	received signal strength indicator
Rx	receiver, receive
SBAS ..	Satellite-Based Augmentation System
Tracker	any variant of the Industrial GPS Asset Tracker
TTF ...	time to first fix
TRM ...	technical reference manual
Tx	transmitter, transmit
UG	user guide (this document)
UTC	Coordinated Universal Time
UV	ultraviolet
ver.	version

1 Product Description

1.1 Overview

This User Guide is intended to be a user manual for *the Industrial GPS Asset Tracker*, henceforth referred to as *the Tracker* for brevity, developed by TEKTELIC Communications Inc.

The Tracker is a multi-purpose LoRaWAN IoT asset tracker intended to allow assets to be located via a LoRaWAN network. The location is obtained from a GNSS receiver. The Tracker is equipped with an IoT targeted MCU that has Bluetooth compatibility, a LoRa-based radio, a GNSS device, an accelerometer, and three battery gauges. Table 1-1-1 presents the available Tracker model.

Table 1-1-1: Industrial GPS Asset Tracker Model

Product Code	Description	RF Region	Tx Band (MHz)	Rx Band (MHz)
T0006129	Industrial GPS Asset Tracker, 2X D-Cell	US915 EU868	923-928 863-870	902-915 863-870

The main features of the Tracker are the following:

- **GNSS:** Supports GPS, Galileo, GLONASS, BeiDou, QZSS, and SBAS.
- **BLE:** Bluetooth as a backup positioning system.
- **Accelerometer:** High sensitivity device that can measure any shock or movement events.
- **Battery Gauges:** Fuel gauges for LTC batteries that can provide accurate results with ultra-low average power consumption.

Figure 1-1 illustrates the Tracker in the enclosure.

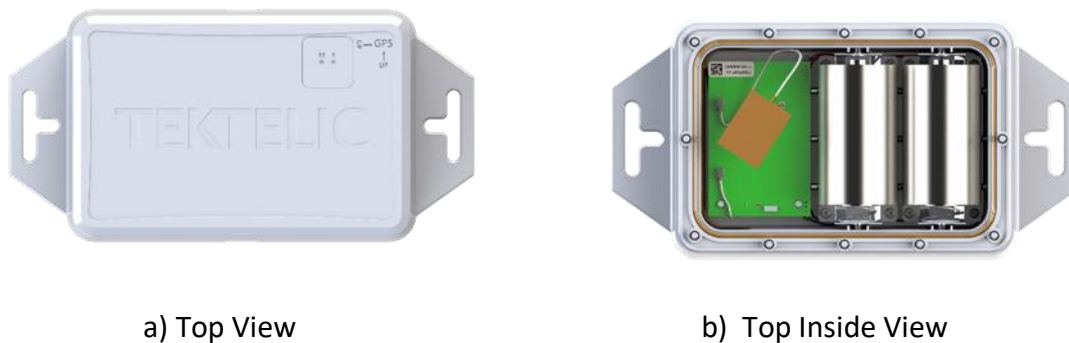



c) Bottom View



d) Isometric Top View

Figure 1-1: The Industrial GPS Asset Tracker module.

1.2 Specifications

The Tracker specifications are listed in Table 1-1-2.

Table 1-1-2: Industrial GPS Asset Tracker Specifications

Parameter	Specification
Use Environment	Industrial Indoor/outdoor commercial/residential
Environmental Rating	IP67
Enclosure	Custom design by TEKTELIC
Humidity Vent	Mobi 3-FJ-S1-00-055 UV rated as part of other safety filings
Operating Temperature	-40°C–85°C
Storage Temperature for Optimal Battery Life	-40°C–75°C
Operating Relative Humidity	0%–100%, condensing
Storage Relative Humidity	0%–100%, condensing
Size	195 mm x 101 mm x 50 mm
Weight	300 g without battery; add 95 g per battery.
Power Source	Battery powered: 1x or 2x D-cell LTC (or 3.0 V–3.7 V DC) with reverse polarity protection
Network technology/Frequency band	LoRaWAN in two variants (see Table 1-1-1): US915, EU868
Air Interface	LoRa
Maximum Tx Power	22 dBm
Sensing Functions	GNSS, Accelerometer, BLE, Temperature, Battery Fuel Gauge
GNSS Features	Support of GPS/QZSS, GLONASS, Galileo, BeiDou Support of 3 concurrent GNSSs Data logging up to 15,000 entries Geofencing up to 4 circular geofences 2.5 m position accuracy TTFF: <ul style="list-style-type: none"> • 26 sec cold start • 1 sec hot start

	Sensitivity: <ul style="list-style-type: none"> • -164 dBm tracking and navigation • -148 dBm cold start • -157 dBm hot start
Accelerometer Sensitivity	Sample rate: 1 Hz, 10 Hz, 25 Hz, 50 Hz, 100 Hz, 200 Hz, 400 Hz Measurement range: $\pm 2 g$, $\pm 4 g$, $\pm 8 g$, $\pm 16 g$ Precision: 16 mg, 32 mg, 64 mg, 192 mg
Bluetooth Compatibility	BLE base on Bluetooth 5
BLE Sensitivity (0.1% BER)	125 kbps: -103 dBm 500 kbps: -98 dBm 2 Mbps: -91 dBm
Temperature Measurement Accuracy	$< \pm 1^{\circ}\text{C}$ between -20°C and 85°C Between -40°C to -20°C
LED	Green: Joining the network activity Red: LoRa Tx or Rx activity
Battery Fuel Gauge Features	3x gauges for up to three LTC batteries Measuring battery voltage, battery current, temperature
Battery Lifetime	1.5 years per battery

2 Installation

2.1 Included Product and Installation Material

The following items are shipped with each Tracker:

- Industrial GPS Asset Tracker in a ruggedized IP67 polycarbonate enclosure with D-cell LTC batteries installed
- Magnet to wake up the Tracker from DEEP SLEEP (activate the Tracker)

2.2 Safety Precautions

The following safety precautions should be observed:

- Use only LTC cells.
- Should the Tracker be opened and powered externally, do not exceed the maximum specified terminal voltages.
- All installation practices must be in accordance with the local and national electrical codes.

2.3 Unpacking and Inspection

The following should be considered during the unpacking of a new Tracker:

- Inspect the shipping carton and report any significant damage to TEKTELIC.
- Unpacking should be conducted in a clean and dry location.
- Do not discard the shipping box or inserts as they will be required if a unit is returned for repair or re-configuration.

2.4 Commissioning and Activation

The Tracker is shipped in closed enclosure with the batteries installed and engaged. However, the Tracker is in a state of DEEP SLEEP where it draws infinitesimal current, until it is woken up (activated) by the provided magnet¹.

The Tracker does not need to get opened for activation. Assuming that the Tracker has been commissioned on the NS, use the magnet to wake up the Tracker as illustrated in Figure 2-1. A magnet presence is achieved by attaching the magnet to the enclosure at the magnet sign. A magnet absence is achieved by taking the magnet at least 2 cm away from the enclosure.

Here are the steps as illustrated in Figure 2-1:

¹ Any magnet almost as strong as Standex-Meder M4, M5, or M13 can be used as well.

1. Attach the magnet, then take it away, then attach it back again, all at a normal pace.
2. Keep magnet attached to the enclosure at the magnet sign for at least 3 sec but less than 10 sec.

As soon as the specified magnetic pattern is applied to the Tracker, the Tracker is reset and tries to join the network. See section 4.3 for the expected LED behaviour of the Tracker during the join process. It may take about 10-15 sec from the Tracker reset to seeing the LED activity showing join attempts.

Note that the specified magnetic pattern always triggers a module reset, even during normal operation. Such a reset also activates an already in-DEEP-SLEEP module.

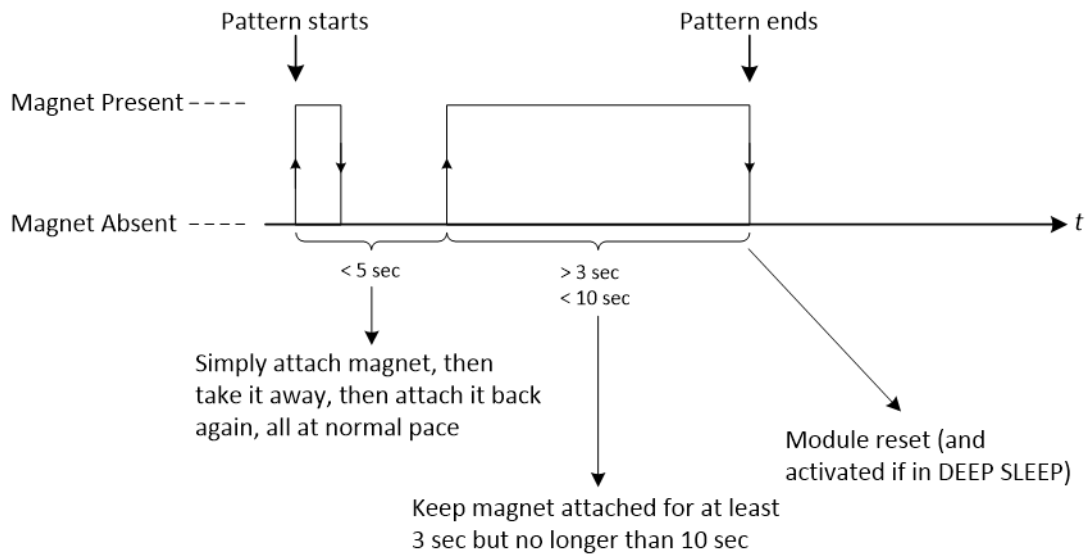

Figure 2-1: The Tracker magnetic reset/wake-up pattern.

The Tracker can be put into DEEP SLEEP at anytime by opening it up and pressing the internal sleep button labeled as SW2 and located visibly on top of the Tracker PCBA. If put to DEEP SLEEP, the Tracker can be woken up (activated) again using the same procedure explained above, i.e. by the use of the magnet. Removing and reinserting the batteries can also activate the Tracker.

Note: Replacing the batteries of the Tracker does not cause the Tracker to go to DEEP SLEEP. As soon as new batteries are inserted, the Tracker boots up and tries to join a LoRaWAN.

2.5 Mounting

On either side of the enclosure there are two mounting holes, see Figure 2-2. These mounting holes can be used to screw the enclosure to a solid surface. The mounting holes are T-shaped slots so the device can be secured with ropes, zip ties or screws depending on the user's needs. The recommended mounting screw size is M3. Mounting screws are not provided with the Tracker.

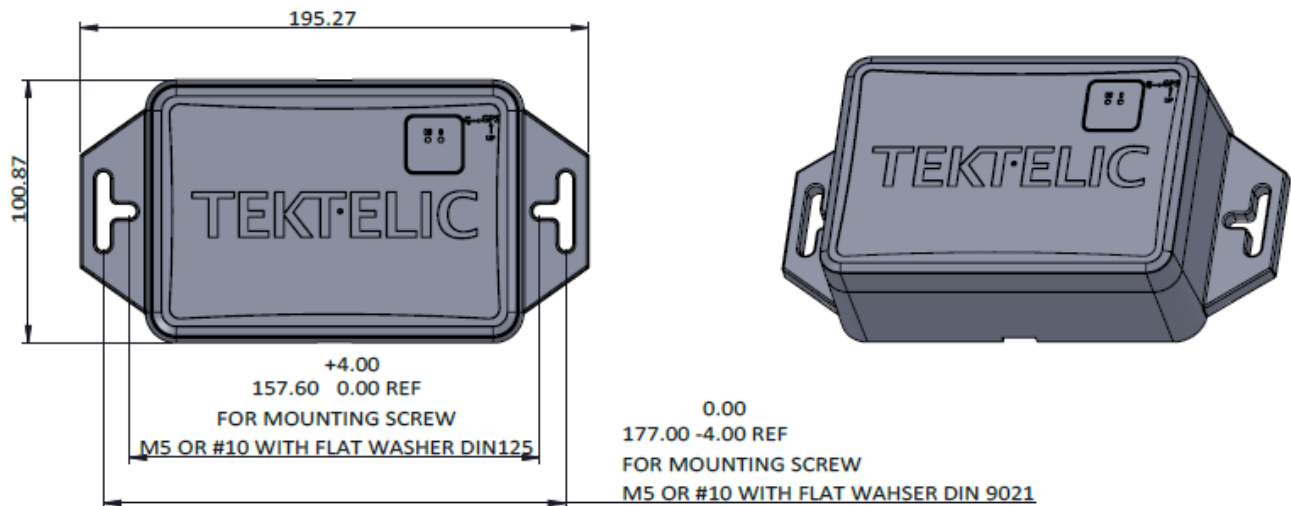

Figure 2-2: The mounting holes and enclosure screw holes.

The mounting surface must be capable of holding > 2 kg (4.5 lbs).

2.6 Battery Replacement

Open up the Tracker using a #2 Phillips screwdriver. The Tracker has 12x enclosure Philips screws at the bottom. Be careful not to misplace the silicone cover gasket.

Replace the battery(-ies). The Tracker accepts D-size, 3.6 V, LTC batteries. The Tracker can operate with one or two batteries. One battery yields half the capacity of a two-battery module. In the case of one battery, the battery can be inserted in any of the two battery holders. Suggested replacement batteries include,

- Tadiran TL-4930/S or TL-5930/S
- Xeno Energy XL-205F STD
- Saft LS33600

Once the Tracker is powered and tries to join (see Section 3.3 for LED behavior), replace the cover and gasket. Make sure that the gasket is properly seated in the cover before placing on the Tracker housing. Tighten the 12 cover screws to 2.5 lbf-in (30 N-cm).

3 Operation, Alarms, and Management

3.1 Configuration

The Tracker supports a full range of OTA configuration options. Specific technical details are available in the Tracker TRM. All configuration commands need to be sent OTA during a Tracker's DL windows.

3.2 Default Configuration

The default configuration on the Tracker is:

- Report the battery voltages once every day.
- Report UTC and GNSS position fix coordinates once every hour.
- Scan and report up to 8 discovered BLE devices with the largest RSSIs once every 6 hours.
- Report the battery voltages when the magnetic switch is triggered 3 times in 3 sec.

3.3 LED Behaviour

See Figure 1-1 for the location and identification of the Tracker LEDs.

During the boot and join process:

- Both LEDs will come on briefly when power is first applied.
- After a small delay (< 1 second) the LEDs will turn off and one of them will blink briefly.
 - If the System (green) LED blinks, then all health checks on the board have passed.
 - If the LoRa (red) LED blinks, then one of the health checks has failed. Consider replacing the batteries, or moving the Tracker to an environment within the temperature range.
- Immediately after the delay, the join procedure will begin. During this time the System LED blinks for 1 sec every 10 sec until the Tracker joins a network.
- During normal operation, the LoRa LED blinks whenever LoRa activity occurs on the Tracker (transmitting or receiving packets).

3.4 Activation, Putting to DEEP SLEEP, Resetting, and Shutting Down

Table 3-1 shows how to activate, put to DEEP SLEEP, reset, or completely turn off the Tracker.

Table 3-1: How to Activate, Put to DEEP SLEEP, Reset, or Shut Down Tracker

Desired Action	What to Do
Activate out of DEEP SLEEP	<ul style="list-style-type: none">• Apply the specified magnetic pattern described in Section 2.4 to the Tracker (no need to open the Tracker) OR: <ul style="list-style-type: none">• Remove and reinsert the batteries

Put to DEEP SLEEP	<ul style="list-style-type: none"> • Open the Tracker and press the reset button on the PCBA
Reset	<ul style="list-style-type: none"> • Apply the specified magnetic pattern described in Section 2.4 to the Tracker (no need to open the Tracker) <p>OR:</p> <ul style="list-style-type: none"> • Remove and reinsert the batteries
Completely power off	<ul style="list-style-type: none"> • Remove the batteries

NOTE: Shutting down or resetting the Tracker will cause all unsaved user configurations to be lost. Save your desired configuration to the Tracker flash before powering off, putting to DEEP SLEEP, or resetting the Tracker.

4 Compliance Statements

Federal Communications Commission:

This device complies with Part 15 of the FCC Rules. Operation is subject to the following two conditions:

1. This device may not cause harmful interference, and
2. This device must accept any interference received, including interference that may cause undesired operation.

To comply with FCC exposure limits for general population / uncontrolled exposure, this device should be installed at a distance of 20 cm from all persons and must not be co-located or operating in conjunction with any other transmitter.

Changes or modifications not expressly approved by the party responsible for compliance could void the user's authority to operate the equipment. This equipment has been tested and found to comply with the limits for a Class B digital device, pursuant to Part 15 of the FCC Rules. These limits are designed to provide reasonable protection against harmful interference in a residential installation. This equipment generates uses and can radiate radio frequency energy and, if not installed and used in accordance with the instructions, may cause harmful interference to radio communications. However, there is no guarantee that interference will not occur in a particular installation. If this equipment does cause harmful interference to radio or television reception, which can be determined by turning the equipment off and on, the user is encouraged to try to correct the interference by one of the following measures:

- Reorient or relocate the receiving antenna.
- Increase the separation between the equipment and receiver.
- Connect the equipment into an outlet on a circuit different from that to which the receiver is connected.
- Consult the dealer or an experienced radio/TV technician for help.

Innovation, Science and Economic Development Canada (Industry Canada):

This device contains licence-exempt transmitter(s)/receiver(s) that comply with Innovation, Science and Economic Development Canada's licence-exempt RSS(s). Operation is subject to the following two conditions:

- (1) This device may not cause interference, and
- (2) This device must accept any interference, including interference that may cause undesired operation of the device.

This device should be installed and operated with minimum distance 0.2 m from human body.

L'émetteur/récepteur exempt de licence contenu dans le présent appareil est conforme aux CNR d'Innovation, Sciences et Développement économique Canada applicables aux appareils radio exempts de licence. L'exploitation est autorisée aux deux conditions suivantes:

- (1) L'appareil ne doit pas produire de brouillage.
- (2) L'appareil doit accepter tout brouillage radioélectrique subi, même si le brouillage est susceptible d'en compromettre le fonctionnement.

Cet appareil doit être installé et utilisé à une distance minimale de 0.2 m du corps humain.

California Proposition 65:

 **WARNING:** This product can expose you to chemicals including lead, nickel, and carbon black, which are known to the State of California to cause cancer, birth defects or other reproductive harm. For more information, go to www.P65Warnings.ca.gov.

References

- [1] LoRa Alliance, "LoRaWAN Specification," ver. 1.0.2, July 2016.
- [2] LoRa Alliance, "LoRaWAN 1.0.2 Regional Parameters," rev. B, Feb 2017.